

MODEL#	COOKING SURFACE
A790i	792 SQ. IN. [36"x 22"] (SHOWN)
A660i	660 SQ. IN. [30"x 22"]
A540i	540 SQ. IN. [30"x 18"]
A530i	528 SQ. IN. [24"x 22"]
A430i	432 SQ. IN. [24"x 18"]



## feature highlights

- ◆ A grill of superior design and engineering--crafted for cooking versatility, durability and long life.
- ◆ Sleek styling with seamless control panel
- ◆ Double-walled tear-drop hood with warming rack
- ◆ Push button 9 volt battery operated ignition system
- ◆ Built-in digital thermometer with meat probe ⊕
- ◆ Industry exclusive cast stainless steel "E" burner
- ◆ Stainless steel valve manifold
- ◆ Polished "Comfort Touch" control knobs
- ◆ Optional recessed stainless steel rotisserie backburner and heavy-duty rotisserie kit
- ◆ Built-in storage rack for rotisserie spit rod
- ◆ Infrared burner option
- ◆ Water and rain resistant construction
- ◆ Industry's best warranty.

Fire Magic has been  
manufacturing outdoor  
grills for over 60 years!

⊕ patent pending



SAVOR THE MOMENT

CRAFTED WITH PRIDE  IN THE USA

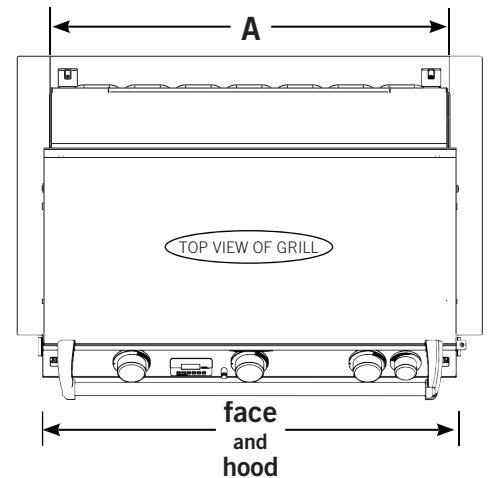
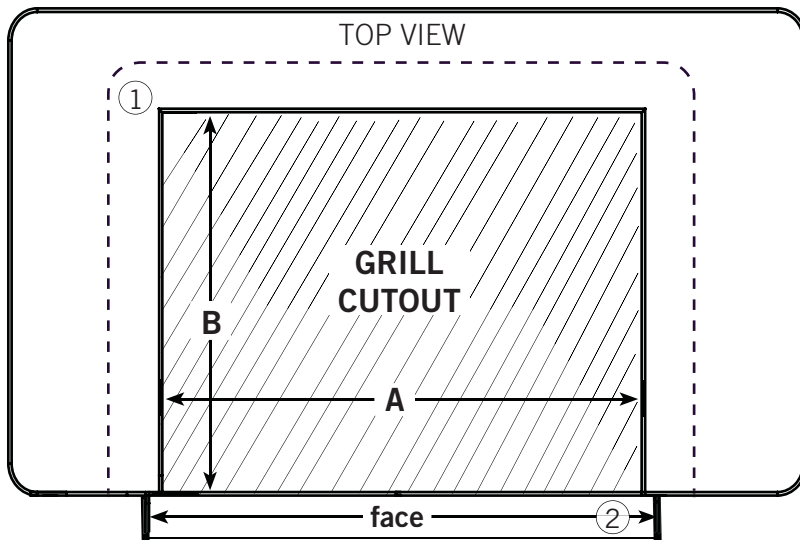

••OPENING REQUIRED••

MODEL#	WIDTH	DEPTH	HEIGHT	FACE
	A	B	C	
Aurora A790i	37 <sup>3</sup> / <sub>4</sub> "	23 <sup>1</sup> / <sub>2</sub> "	12"	38 <sup>1</sup> / <sub>4</sub> "
Aurora A660i	32 "	23 <sup>1</sup> / <sub>2</sub> "	12"	32 <sup>1</sup> / <sub>2</sub> "
Aurora A540i	32"	19 <sup>1</sup> / <sub>2</sub> "	12"	32 <sup>1</sup> / <sub>2</sub> "
Aurora A530i	25 <sup>1</sup> / <sub>2</sub> "	23 <sup>1</sup> / <sub>2</sub> "	12"	26 <sup>1</sup> / <sub>2</sub> "
Aurora A430i	25 <sup>1</sup> / <sub>2</sub> "	19 <sup>1</sup> / <sub>2</sub> "	12"	26 <sup>1</sup> / <sub>2</sub> "

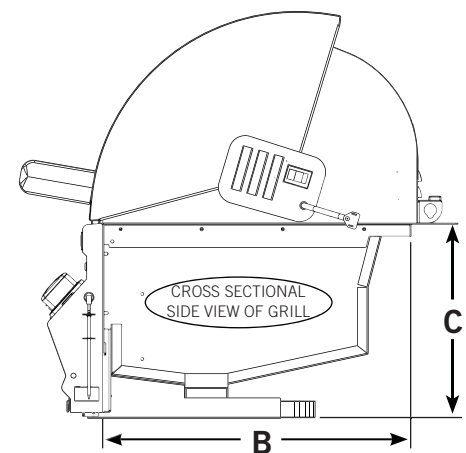

Notes:

1. There is a hanger on all three sides of the cutout. This hanger is 2<sup>1</sup>/<sub>4</sub>-2<sup>1</sup>/<sub>2</sub>" wide. A support shelf is **not** required; front support adjustment screws are provided for additional support.
2. The face of the grill is, on each side, 1/2-3/4" wider than the cutout width. This conceals the cutout space.  
The face and hood are the same width (left-right); both are wider than cutout. The face protrudes 3" from the cutout at its furthest point
3. Additional clearances of 10" on each side, and 3" at the rear are recommended for unrestricted operation of hood, rotisserie, and accessories.

A FIRE MAGIC GRILL PROVIDES THE VERSATILITY TO BAKE A CAKE OR SEAR A STEAK. REGULATED, CONTROLLED HEAT ALLOWS SLOW COOKING---UP TO OVER 1000° AT COOKING SURFACE.

